

Main characteristics

- The PMI-12 transducer is designed for use inside oil-pressure cylinders, applications that demand high strength.
- The AISI316 stainless steel body and elevated protection level permit installation in cylinders with pressures up to 250 bar (400 bar peak).
- Available with internal flanges or external threads to guarantee mechanical compatibility with all principal cylinder types.
- Patented

TECHNICAL DATA

Useful electrical stroke (C.E.U.)	50 to 1000 mm
Independent linearity (within C.E.U.)	see table
Resolution	Infinite
Repeatability	≤ 0.08 mm
Electrical connection	1 mt. 3-pole shielded cable
Displacement speed	standard ≤ 5 m/s
Max. acceleration	≤ 10m/s ² max displacement
Cursor dragging force	≤ 0.5 N
Vibrations	5...2000 Hz, Amax = 0.75 mm amax = 20 g
Shock	50 g, 11 ms
Displacement sensitivity (no hysteresis)	0.05 to 0.1 mm
Tracking error	see table
Tolerance on resistance	± 20%
Recommended cursor current	< 0.1 μA
Maximum cursor current in case of bad performances	10 mA
Maximum applicable voltage	see table
Electrical isolation	> 100 MΩ at 500 V = 1 bar, 2 s
Dielectric strength	< 100 μA at 500 V ~ 50 Hz, 2 s, 1 bar
Dissipation at 40°C (0 W at 120°C)	see table
Thermal coefficient of resistance	-200...+200 ppm/°C typical
Actual Temperature coefficient of the output voltage	≤ 5 ppm/°C typical
Working temperature	-30...+100°C
Storage temperature	-50...+120°C
Material for transducer case	Steel AISI 316
Important: All the data reported in the catalogue linearity and temperature coefficients are valid for a sensor utilization as a ratiometric device with a max current across the cursor circuit I _c ≤ 0.1 μA.	

MECHANICAL DIMENSION

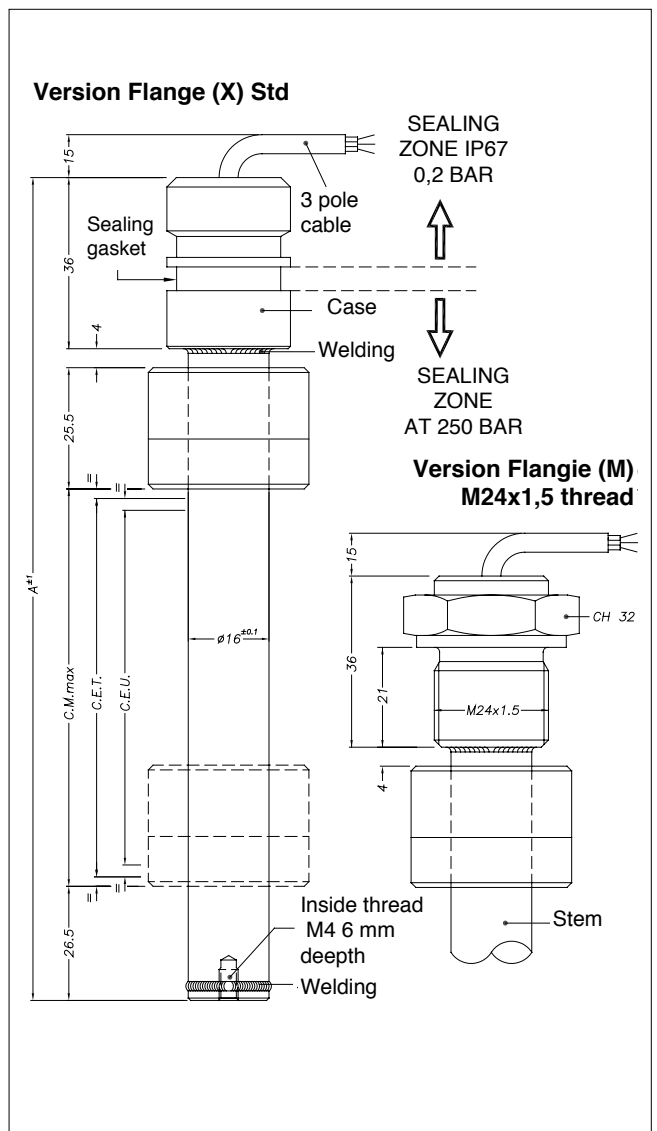

MECHANICAL / ELECTRICAL DATA

MODEL		50	100	150	200	250	300	350	400	450	500	550	600	650	700	750	800	850	900	950	1000
Useful electrical stroke (C.E.U.) + 1 / -0	mm	Model																			
Theoretical electrical stroke (C.E.T.) ± 1	mm	C.E.U. + 1																			
Resistance (C.E.T.)	kΩ	5					10					20									
Independent linearity (within C.E.U.)	±%	0,1					0,05														
Dissipation at 40°C (0W at 120°C)	W	1	2	3																	
Max applicable voltage	V	60																			
Mechanical stroke CM	mm	C.E.U. + 5																			
Case Lenght (A)	mm	C.E.U. + 97																			

PCUR032 CURSOR

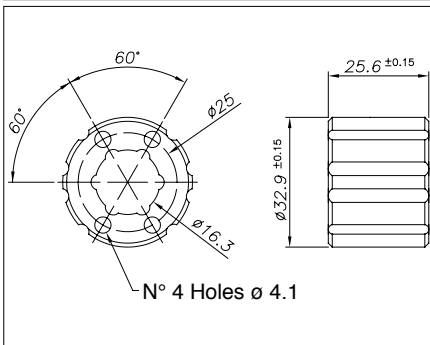

STANDARD FLANGE (X)

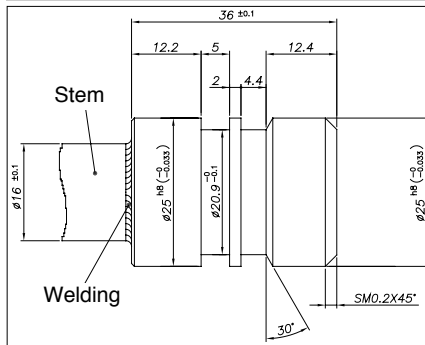

THREADED FLANGE (M)

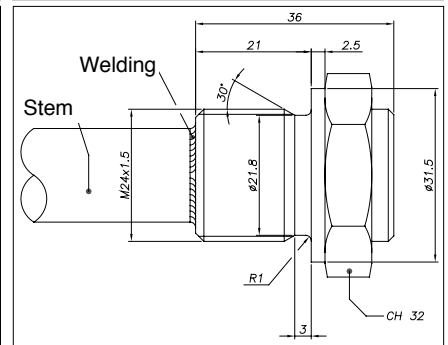

INSTALLATION INSIDE THE CYLINDER

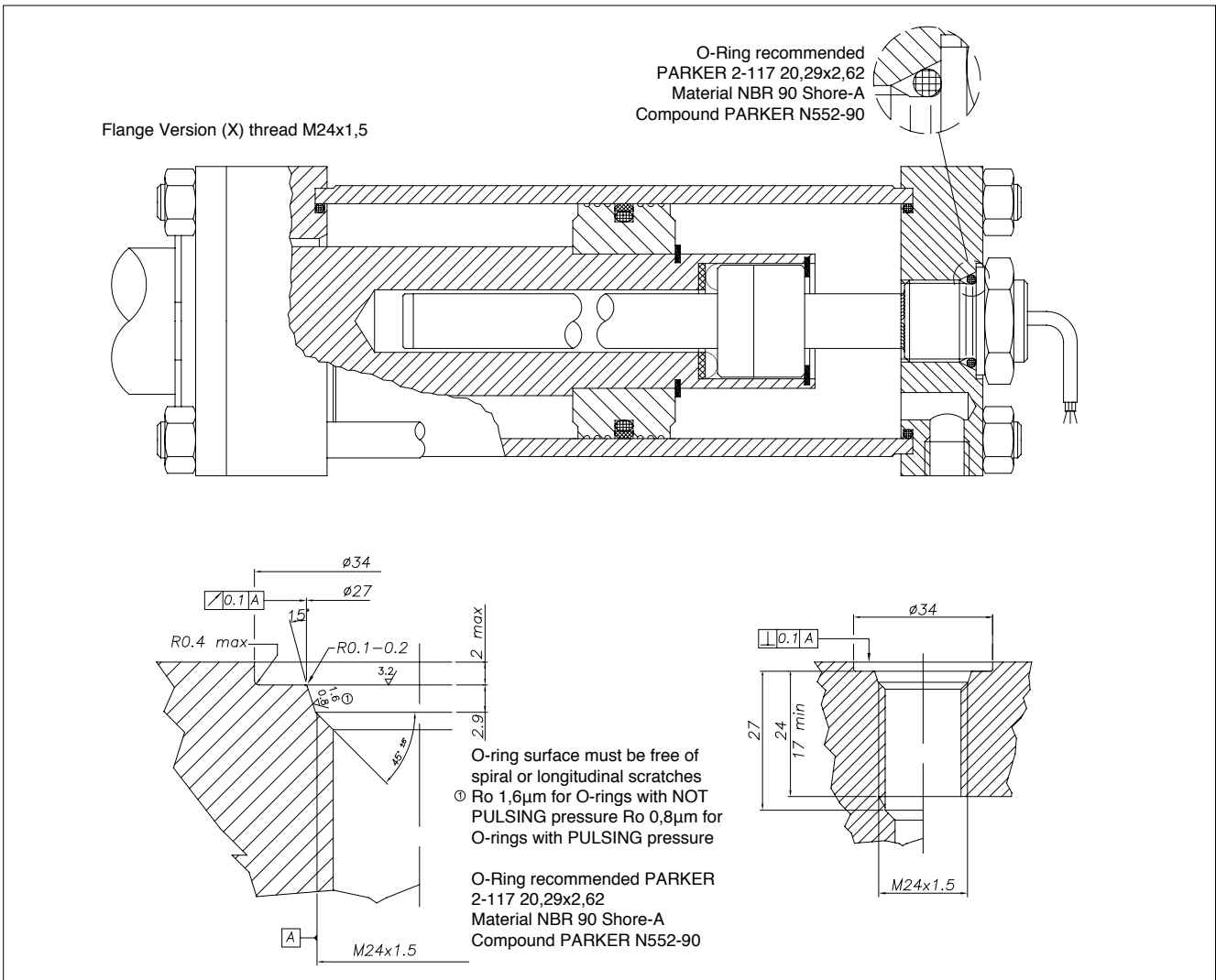

INSTALLATION INSIDE THE CYLINDER

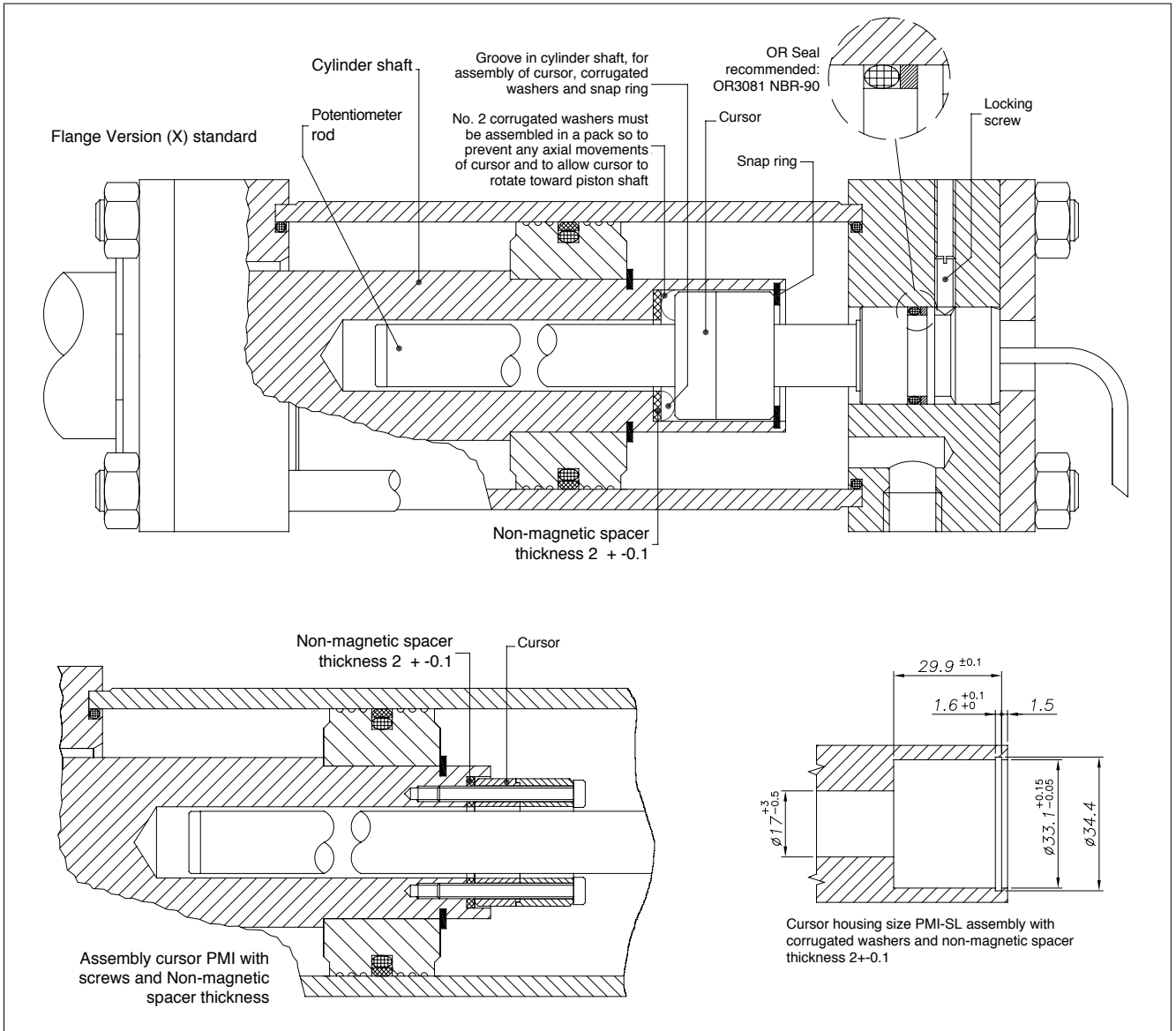

ELECTRICAL CONNECTIONS

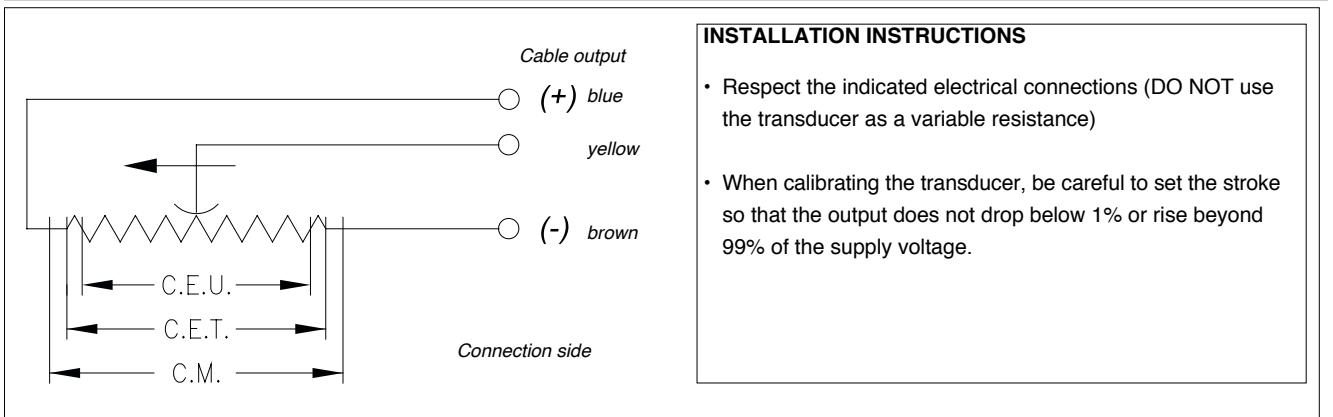

TRACKING ERROR

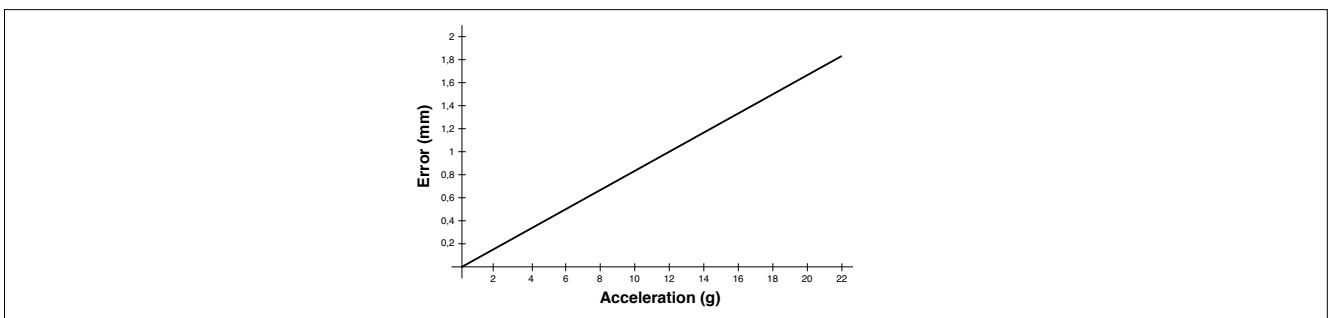

ORDER CODE

Displacement transducers

PMI 12 F

0 0 0 0 X 0 0 0 X X 0 0 X X X

Dimensions 1/2"

3-pole PUR cable output 3x0,25 1m

Model

FLANGE

Standard	X
Threaded M24x1,5	M

CABLE LENGHT (1mt F standard version)

F output 00 =1mt 02 =2mt 03 =3mt 04 =4mt 05 =5mt
10 =10mt 15 =15mt

If requested, it is possible to supply models with non-standard mechanical and/or electrical features

Ex.: **PMI-12-F-400-X 0000-X000-XX-00-XXX**
PMI 12 model transducer, useful electrical stroke (C.E.U.) 400mm.

ACCESSORIES

Series

- Standard magnetic cursor:

PCUR032

GEFRAN spa reserves the right to make any kind of design or functional modification at any moment without prior notice